

| Cable | Ø | R min. |
|-------|------|--------|
| 4x1.5 | 8.6 | 103 |
| 4x2.5 | 10.8 | 130 |
| 4x4 | 12.2 | 147 |
| 4x6 | 14 | 168 |
| 4x10 | 17.6 | 211 |

Cable output length 2m:

Power :

One shielded class 6
cable coded
1,2,3 green/yellow

Thermal sensors :

One shielded class 6
cable (2x2x0.25mm²)

Brown-White : PTC

Green-Yellow : KTY84

Minimum bending radius

(except for the first 50mm) :

See Table

ZONE FREE OF ANY PART
(cable passing)

NO STRESS, NO BENDING, IN THIS AREA

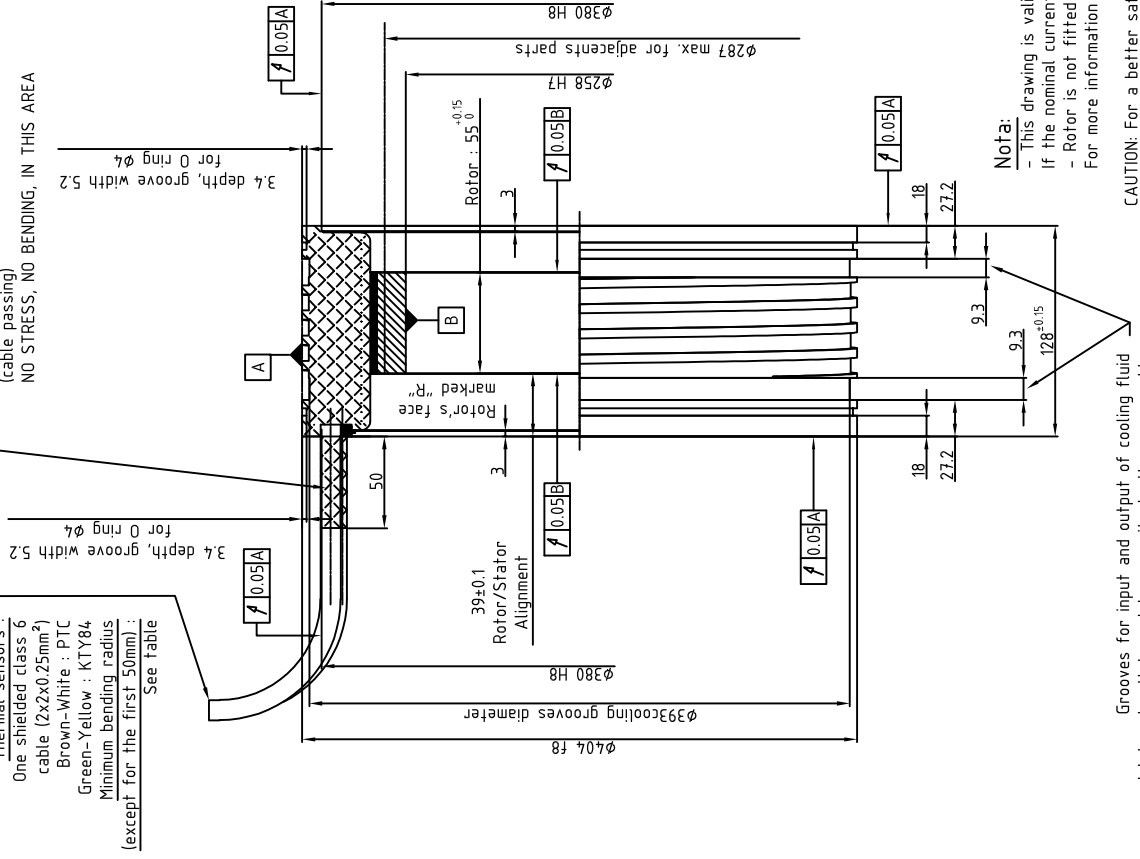

2 series of 12 equidistant holes M6
One serie on each stator face
Angularly aligned series

2 series of 12 equidistant holes M6
One serie on each rotor face
Angularly aligned series

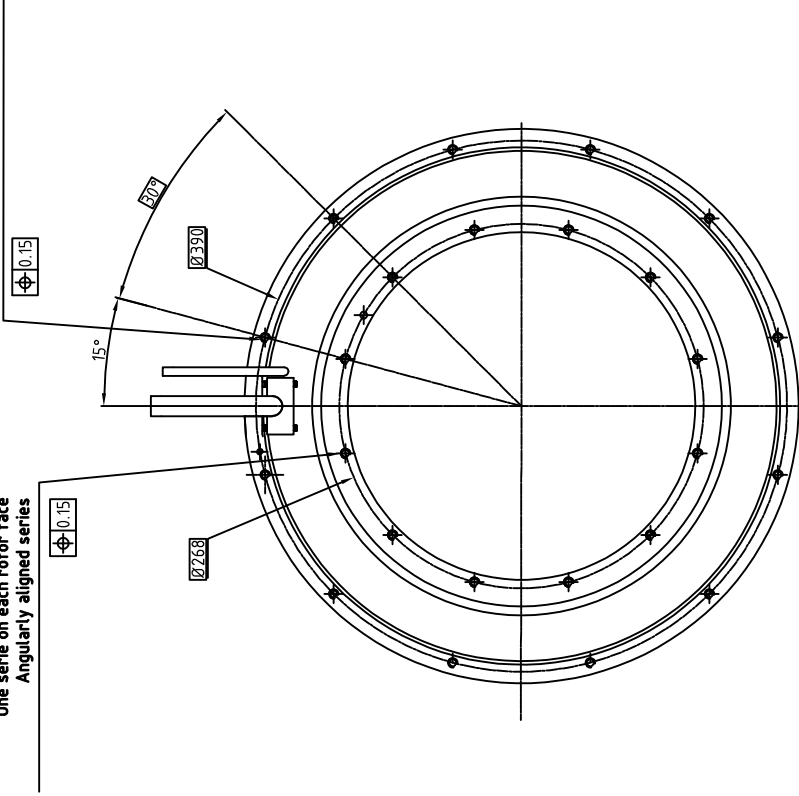

Nota:

- This drawing is valid only for motors with nominal current lower than 53 Amps.
 - If the nominal current is greater than 53 Amps, please contact us.
 - Rotor is not fitted in the stator
- For more information about mounting see document 400STK0-WA002

Grooves for input and output of cooling fluid
Inlet and outlet must be opposite to the power cable

CAUTION: For a better safety, it is recommended that the cooling fluid inlet would be made through the hose located on the side opposed to the cabling, while the cooling fluid outlet will be made by the one located on the cable side.

ALXION

AUTOMATIQUE & PRODUCTIQUE
Parc Technologique des Fossés Jean
92712 COLOMBEES Cedex
Tél: 0141306304 - Fax: 0141306136

400STK2M2XXXXXX