

Cable output length 2m:

- Power:  
 One shielded class 6 cable coded 1,2,3 green/yellow square section and diameter depending of current see table  
 Thermal sensors:  
 One shielded class 6 cable (2x2x0.25mm<sup>2</sup>) overall  $\phi$  7  
 Brown-White : PTC  
 Green-Yellow : KTY84  
 Minimum bending radius (except for the first 50mm):  
 See table

Cable	$\phi$	R min.
4x1.5	8.6	103
4x2.5	10.8	130
4x4	12.2	147
4x6	14	168
4x10	17.6	211

ZONE FREE OF ANY PART  
 (cable passing)  
 NO STRESS, NO BENDING, IN THIS AREA.

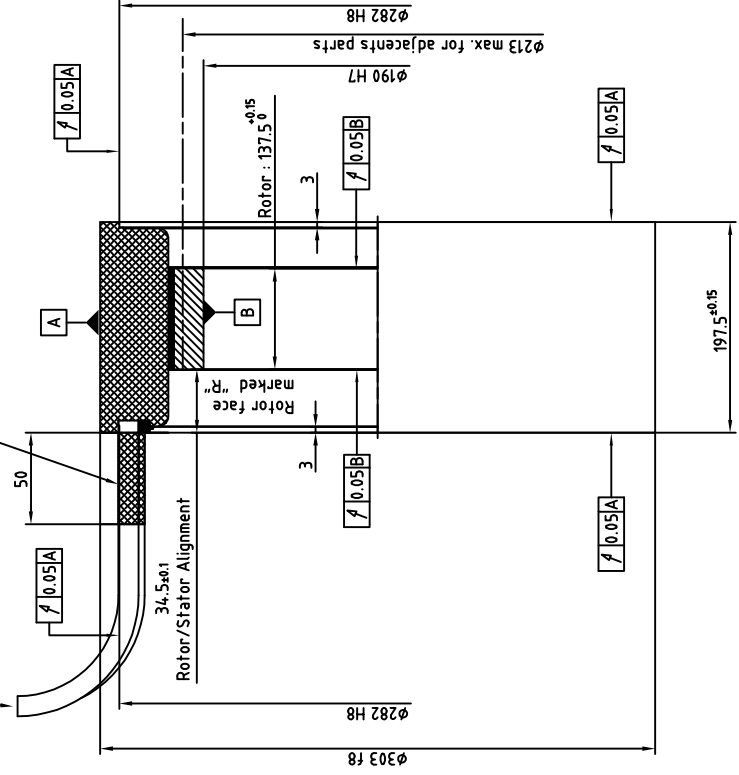

2 series of 12 equidistant holes M5x12  
 One serie on each stator face  
 Angularly aligned series

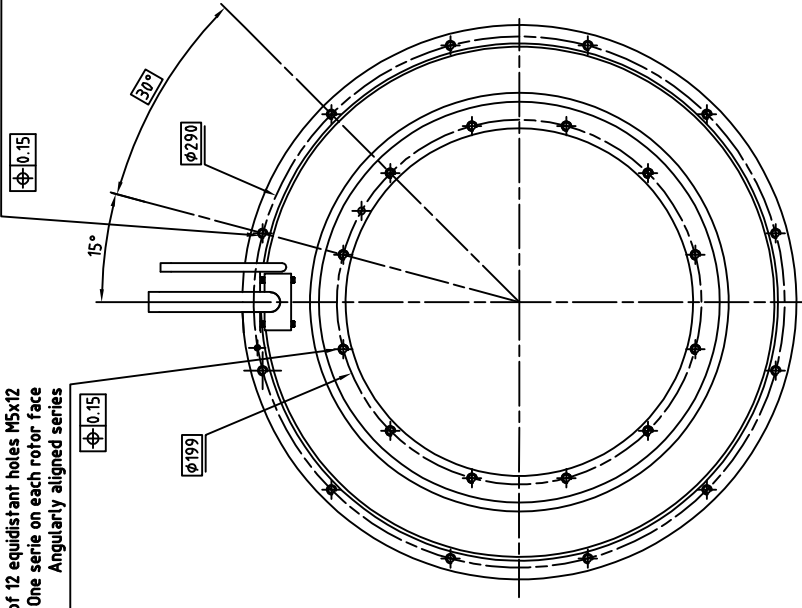

2 series of 12 equidistant holes M5x12  
 One serie on each rotor face  
 Angularly aligned series

NOTA:  
 Rotor is not fitted in the stator  
 For more information about mounting see  
 document 300STK0-WA002

**ALXION**  
 AUTOMATIQUE & PRODUCTIQUE  
 Parc Technologique des Fossés Jean  
 92712 COLONBES Cedex  
 Tél: 014-1306304 - Fax: 014-1306136

300STK5M1XXXXXX